

Billi™



Superior instant filtered boiling, chilled, still and sparkling water systems for commercial environments

Billi™

Billi has been at the forefront of the instant filtered boiling and chilled water systems industry for over 30 years. Bringing a unique concept of under-bench instant filtered boiling, chilled and sparkling drinking water to many countries around the globe, Billi products are celebrated for their combination of functionality, performance and contemporary aesthetics.

Manufactured to the highest of standards, Billi water systems come with an assurance of quality, innovation and sustainability. Incorporating cutting edge eco-technology features and modern designs, Billi delivers solutions that keep pace with the ever-changing needs of its users.

CONTENTS

About Billi	p.03
Why Billi	p.04
Product Features & Benefits	p.05
IWBI Membership	p.06
Environmental Focus	p.08
Billi Technology	p.09
Product Range	p.10
X Series Dispensers	p.17
Specialty Dispensers	p.18
Luxgarde	p.19
Slimline Dispensers	p.20
Mixer Tapware	p.21
Accessories	p.22
Billi Service	p.23
Premium Filtration	p.24
Warranty & Certifications	p.26

WHY BILLI

Synonymous with innovation, Billi prides itself on being the leading designer and manufacturer of boiling, chilled, sparkling and still filtered water systems.

With all Boiling & Chilled units manufactured in Melbourne, Australia, we are uncompromising on quality and dedicated to delivering the most reliable, high performance and stylish products on the market.

The Billi range of products include industry leading features such as water-cooled technology, space saving under-bench footprints, specialty dispensers, plus a large range of models that do not require cupboard ventilation cut outs or grilles. This makes our units easy to install, energy efficient and user-friendly for all.



XT Dispenser in Matte Black finish with matching 70mm Riser & Font

CUSTOMER FOCUS

In every interaction with Billi, our commitment to the highest levels of customer service is evident.

Billi's unequalled aftersales care and product support, ensures that our valued relationship with our customers does not end at purchase.

Billi goes a step further with dedicated teams servicing each of our markets to ensure specialised care relevant to your requirements.

Our global distribution network is no different. Each international distributor is carefully vetted and approved before being invited to join the Billi global network.

PRODUCT FEATURES & BENEFITS



SPACE SAVING DESIGN

With a focus on space saving, Billi systems have one of the smallest footprints on the market, allowing you to make the most of valuable underbench space.



SAFE TO OPERATE

Billi's X series dispensers are supplied standard with a safety switch to lock off access to boiling water where needed. The red lock icon demonstrates when the safety switch is activated. Simply touch the sensor switch to release the lock and activate the boiling water. The dispenser will revert to safety mode after a period of non-use.



SPLASHFREE DELIVERY

Billi's Splashfree boiling water delivery electronically varies the water flow, slowing momentarily to eliminate splashing as the water first enters the cup.



ENERGY EFFICIENT

Billi's unique Heat Exchange Technology enables our systems to achieve substantial energy savings. Our units also feature a standby mode which conserves energy by powering down after 2 hours of non-use.



HEAT EXCHANGE TECHNOLOGY

Billi's unique heat exchange & energy reclaim technologies recover the waste heat energy produced in the chilling process to preheat the boiling water. This allows boiling water to reach optimal temperature more efficiently while achieving substantial energy savings.



WATER-COOLED and AIR-COOLED TECHNOLOGY

Billi is the only manufacturer to offer both water-cooled and air-cooled options. Our water-cooled systems utilise heat exchange & energy reclaim technologies and are more energy efficient than our air-cooled systems. Billi's heat exchange technology ensures water usage is minimal. Billi's air-cooled options generate far less heat than traditional air-cooled systems.



NO CUPBOARD VENTILATION REQUIRED

Billi's water cooled systems do not require cupboard ventilation or a cooling fan and operate a lot quieter than air cooled systems.



ADJUSTABLE CHILLED TEMPERATURE

A simple adjustable control knob allows the chilled water temperature to be raised to 15°C or lowered to 6°C for perfectly chilled, refreshing drinks. Your desired temperature is reached quickly and maintained efficiently during operation.



ADJUSTABLE SPARKLING LEVEL

Adjust the level of sparkling to suit your taste, with adjustable controls up to 5 bar of CO₂ pressure.



UNLIMITED FILTERED WATER

The Billi Alpine, Sahara and Filter Tap ranges all offer a bottomless supply of still filtered water.*



ICE BANK TECHNOLOGY

Our Ice bank technology has a chilled reservoir where both sparkling and chilled water supply passes through. In doing so, the dispensed water temperature is consistently chilled, also providing a higher level of carbonation.



PLUS MODELS AVAILABLE

Billi's PLUS models can function as your hot water service providing hot and cold water, as well as boiling, chilled, sparkling or still water.

PLUS models also feature a boiling water reserve to ensure you will have a boiling water supply after the hot water supply is fully drawn. Ideal for areas without a hot water supply.



ECO-INTELLIGENCE TECHNOLOGY

The Billi Eco and Sahara systems incorporate Eco-Intelligence technology, which is a self learning timer allowing the unit to only operate when required. The self learning timer monitors daily usage patterns and even recognises evening and weekend changes in routine to effectively minimise energy consumption.



CHOICE OF DISPENSER DESIGNS

The Billi range offers a variety of dispenser options including our X series and slimline dispensers in a selection of modern finishes. Site specific tapware is available, including an XL Levered dispenser with red and blue coloured levers and braille pads for vision impaired applications.



EASY INSTALLATION

By eliminating the need for cupboard cut outs, our units are quick, easy and safer to install. Our units also feature a self commissioning function making setup simple and efficient.



AUSTRALIAN DESIGNED & MADE

All Billi boiling & chilled units are designed and manufactured in Australia.



ACCESSORIES

Billi has a range of stylish and functional accessories to match your needs including fonts, risers and tubing extension kits.



LUXGARDE DEVICE

Luxgarde™ device combines cutting-edge non-chemical UVC LED technology to provide unrivalled protection & purification. Luxgarde™ ensures effective defence against possible waterborne pathogens, providing water that is free from microorganisms, including coliform, salmonella, legionellae, pseudomonas, and even the hepatitis virus.

Luxgarde™ has been designed to keep your water pure, your people safe and your family protected.



HEALTH & WELLNESS

Fully compliant to IWBI's Well Building Initiative. No VOCs or BPA's present and Copper has been replaced with Stainless Steel.

* Safety time-out features and the required filter changes for hygiene still apply.

Since 2019, Billi has been formally affiliated with the International Well Building Institute (IWBI) as a Cornerstone Member. Billi joins like-minded companies from across the globe that are committed to enhancing buildings and communities to help people thrive.

The membership program at IWBI convenes, celebrates and fosters collaboration with companies and organisations who are leading the movement to advance human health in buildings and communities around the world. This dynamic framework allows Billi to tap into IWBI's expansive resources and knowledge and demonstrates Billi's alignment with IWBI's mission.



"IWBI focuses on transforming health and wellbeing with our people-first approach to buildings, organisations and communities. As an IWBI Member, Billi has been an engaged contributor to the WELL movement since 2019 and we continue to enjoy a productive and collaborative relationship between our organisations within the region."

Jack Noonan, Vice President, International WELL Building Institute, Asia Pacific.

ABOUT IWBI

The International WELL Building Institute (IWBI) is leading the global movement to transform our buildings and communities in ways that help people thrive.

The WELL v2 pilot is the recently launched version of its popular WELL Building Standard, which will continue to be offered to the market, along with the WELL Community Standard pilot, a district scale rating system that sets a new global benchmark for healthy communities.

WELL is focused exclusively on the ways that buildings and communities, and everything in them, can improve our comfort, drive better choices, and generally enhance, not compromise, our health and wellness.

IWBI convenes and mobilizes the wellness community through management of the WELL AP credential, the pursuit of applicable research, the development of educational resources, and advocacy for policies that promote health and wellness everywhere.

For more information about IWBI and WELL, please visit: www.wellcertified.com



XL Levered Dispenser in Chrome finish with matching 70mm riser and font



Billi's Environmental Sustainability



Billi is renowned for its eco focus, ensuring our drinking water appliances go beyond water and energy saving. We aim for low environmental impact to enhance the enjoyment of your personal surroundings.

A total quality commitment makes a Billi system the first choice in water appliances – stylish designs combined with impressive performance.

Chilling water creates waste heat energy. Billi's patented technology recovers and reuses energy to preheat the boiling water, thereby saving energy.

Effective water and energy saving initiatives help meet Green Building Design (GBD) objectives. Billi filtered water systems offer unique power consumption advantages:

- Thermodynamic heat-exchange technology recovers and reuses heat energy;
- High performance polyethylene insulation retains water temperature and saves energy.
- Stand-by mode conserves power during set non-use periods.

Billi lets you enjoy pure, clean water without costly environmental impact through achieving optimal water and energy savings.

GreenTag Certification

Global GreenTag is one of the world's most robust, trusted and widely recognised ecolabels which independently assures that every product is fitness tested and certified under leading certification programs that use world's best scientific methods.

They have earned the reputation and trust of thousands of buyers, hundreds of companies and numerous green building councils, certification bodies and governments around the world.

Billi complies with GreenTag International standard v.32 with Gold level certification on the Eco, Quadra and Quadra Plus models.



The assessments required to achieve the Gold level certification includes:

- ✓ Australian Made
- ✓ Building/Product Synergy
 - Makes building & other systems more efficient
 - Multiple purpose product
- ✓ Corporate Social Responsibility
 - Building code of Australia compliant
 - Complies with Australian law
 - Fit for purpose certified
- ✓ Health & Ecotoxicity
 - Considered safe to use
- ✓ LCA
 - Life Cycle Analysis – Greenhouse Gas
 - 'Low carbon'
 - Carbon footprint available
- ✓ Life Cycle Analysis – Water
 - Highly water efficient

Heat Exchange Technology

Billi's unique heat-exchange technology recovers the waste heat energy produced in the chilling process to preheat the boiling water. This allows the boiling water to reach optimal temperature more efficiently while achieving substantial energy savings.

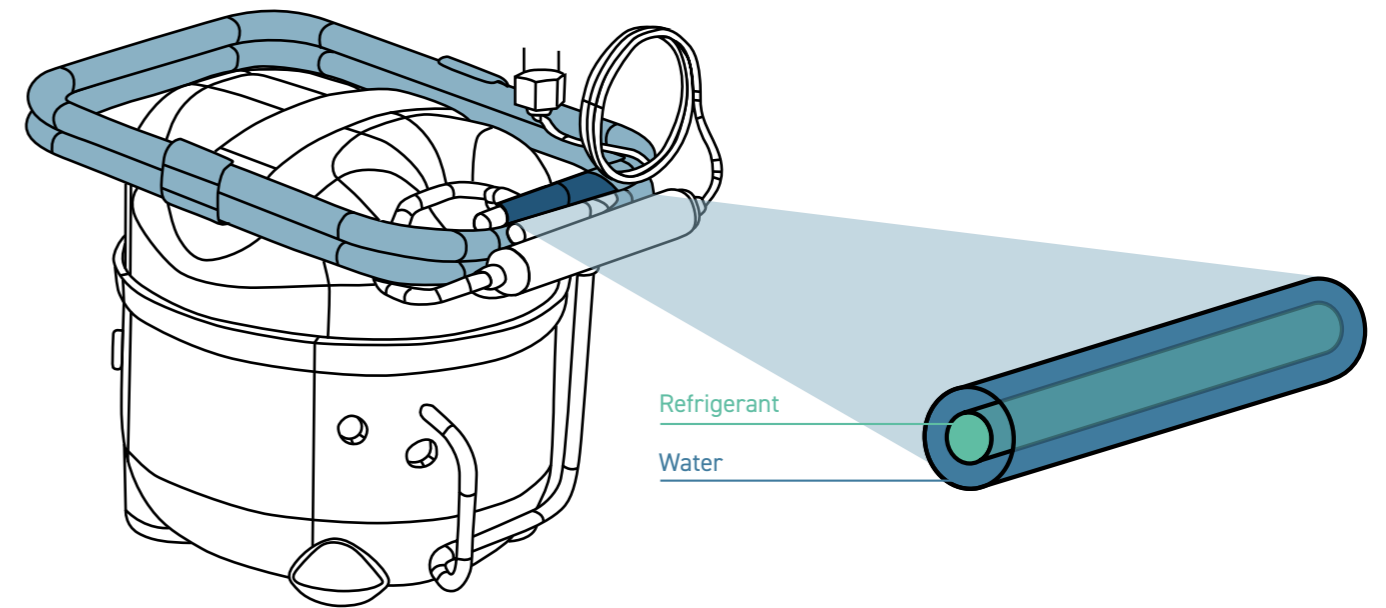

Water-Cooled vs Air-Cooled

Billi is the only manufacturer to offer both water-cooled and air-cooled technology. Our water-cooled systems are a more energy efficient option and Billi's heat exchange technology ensures minimal water usage.

WATER-COOLED TECHNOLOGY

- Billi water-cooled units do not require cupboard ventilation or a cooling fan.
- No cupboard cut-outs or grilles.
- Energy usage is reduced significantly as heat generated during the chilling process is used to preheat the boiling water.



AIR-COOLED TECHNOLOGY

- Billi air-cooled units generate less heat than traditional air-cooled systems.
- No water required for the chilling process.
- Cupboard ventilation recommended.

PRODUCT RANGE



Billi OmniOne Pro60

The OmniOne Pro60 is the latest iteration of multifunction filtered drinking water appliances from Billi.

FEATURES



A CO2 gas cylinder is required and is additional to the product dimensions displayed.

DISPENSER OPTION



Product Code	Model	Suggested no. of people	Boiling water delivery (cups per hour)*	Chilled & Sparkling water delivery (cups per hour)	Power supply (amps)
926060	OmniOne Pro60	up to 60	180	220	1 x 10



Billi OmniOne Plus 9

The OmniOne Pro60 is the latest iteration of multifunction filtered drinking water appliances from Billi.

FEATURES



A CO2 gas cylinder is required and is additional to the product dimensions displayed.

DISPENSER OPTIONS + MIXER TAP OPTIONS



Product Code	Model	50° hot water capacity litres (initial drawdown)	50° hot water delivery litres per hour	Boiling water delivery (cups per hour)*	Chilled water delivery (cups per hour)	Power supply (amps)
926065	OmniOne Plus 9	9	60	180	220	1 x 10

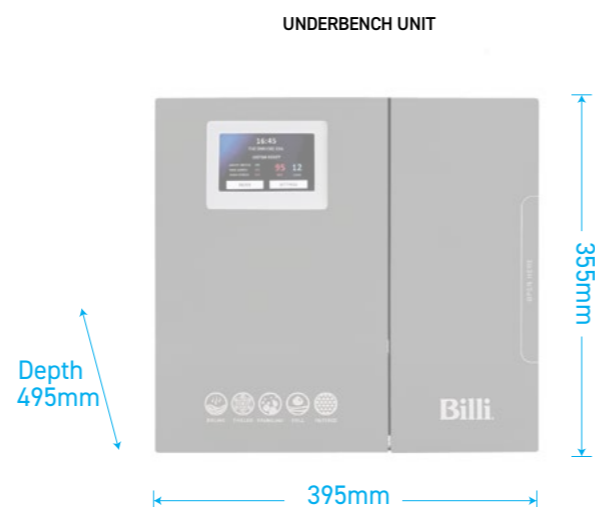
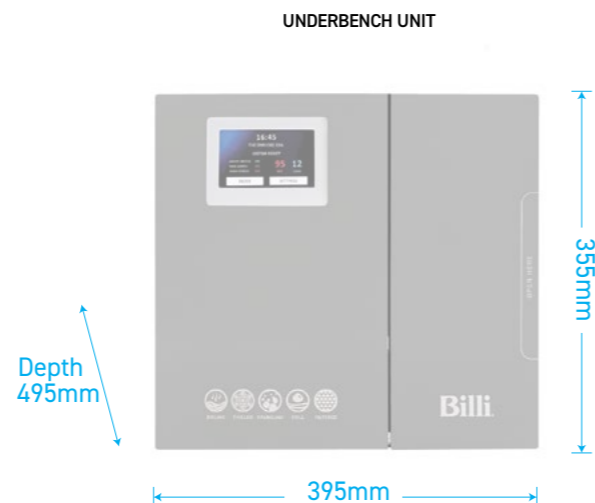

Billi Eco

Instant boiling and chilled filtered water system

FEATURES



DISPENSER OPTIONS



Product Code	Model	Suggested no. of people	Boiling water delivery (cups per hour)*	Chilled water delivery (cups per hour)	Power supply (amps)
901000	Eco	up to 10	90	60	1 x 10

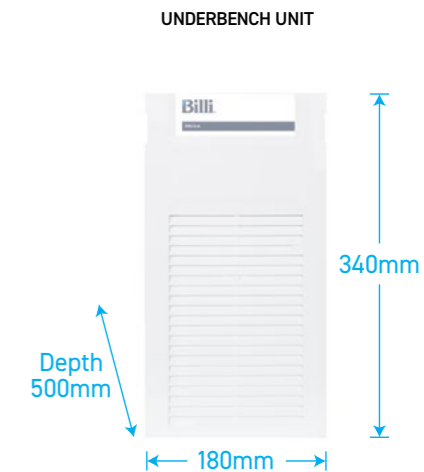

Billi Eco Sparkling

Instant boiling, chilled and sparkling filtered water system

FEATURES



A CO2 gas cylinder is required and is additional to the product dimensions displayed.

DISPENSER OPTION



Product Code	Model	Suggested no. of people	Boiling water delivery (cups per hour)*	Chilled and Sparkling (cups per hour)	Power supply (amps)
906000	Eco Sparkling	Up to 10	90	100	2 x 10

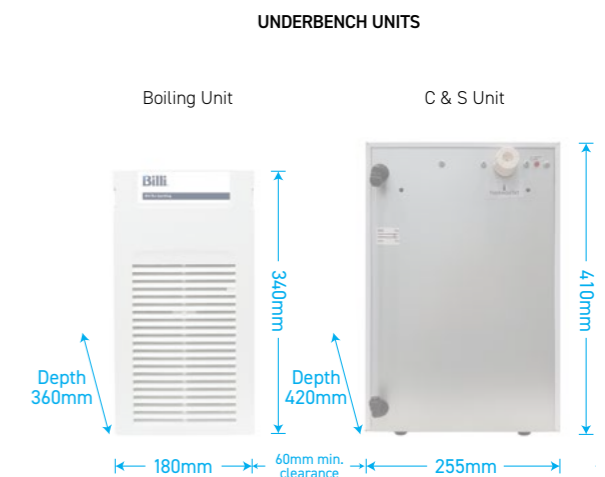

* Based on the initial number of cups of boiling water immediately available, drawn one cup every 10 seconds. For all underbench filtered water systems, consideration may be needed for usage patterns and draw-off methods. 1 cup = 170ml

To specify your product, please combine 'PRODUCT CODE' + 'DISPENSER OPTION' + 'FINISH' + 'COUNTRY CODE' eg to specify a Billi Eco with Lever Chrome dispenser for UAE installation = 901000LCHAE



Billi Quadra

Instant boiling and chilled filtered water system

FEATURES



DISPENSER OPTIONS



Product Code	Model	Suggested no. of people	Boiling water delivery (cups per hour)*	Chilled water delivery (cups per hour)	Power supply (amps)
904010	Quadra Compact	up to 20	100	150	10
904020	Quadra 420	up to 25	120	175	10
904040	Quadra 440	up to 40	150	175	10
904060	Quadra 460	up to 60	180	175	10
904100	Quadra 4100	up to 100	250	175	15
904180	Quadra 4180	up to 180	350	175	20

^ XT not available with Quadra Compact and Quadra 460.



Billi Quadra Plus

Instant boiling and chilled filtered water system plus hot and cold mixer tap. Twin Plus models include 2 separate mixer taps.

FEATURES



DISPENSER OPTIONS + MIXER TAP OPTIONS



Product Code	Model	50° hot water capacity litres (initial drawdown)	50° hot water delivery litres per hour	Boiling water delivery (cups per hour)*	Chilled water delivery (cups per hour)	Power supply (amps)
904025	Quadra Plus 5	7	40	120	175	10
904065	Quadra Plus 9	9	60	180	175	10
904105	Quadra Plus 15	15	85	250	175	15
904107	Quadra Twin Plus 15	15	85	250	175	15
904187	Quadra Twin Plus 21	21	100	350	175	20

* Based on the initial number of cups of boiling water immediately available, drawn one cup every 10 seconds. For all underbench filtered water systems, consideration may be needed for usage patterns and draw-off methods. 1 cup = 170ml

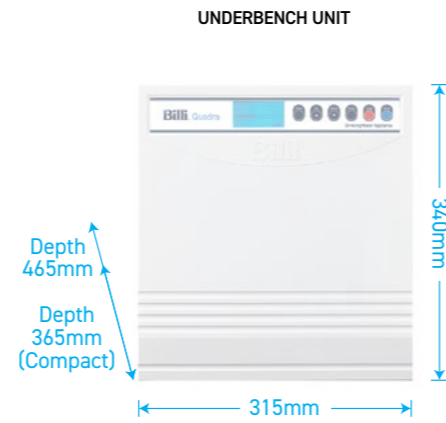

Billi Quadra Sparkling

Instant boiling, chilled and sparkling filtered water system.

FEATURES



A CO2 gas cylinder is required and is additional to the product dimensions displayed.

DISPENSER OPTION



Product Code	Model	Suggested no. of people	Boiling water delivery (cups per hour)*	Chilled & Sparkling water delivery (cups per hour)	Power supply (amps)
906100	Quadra Sparkling 4100	100	250	200	1 x 10 1 x 15

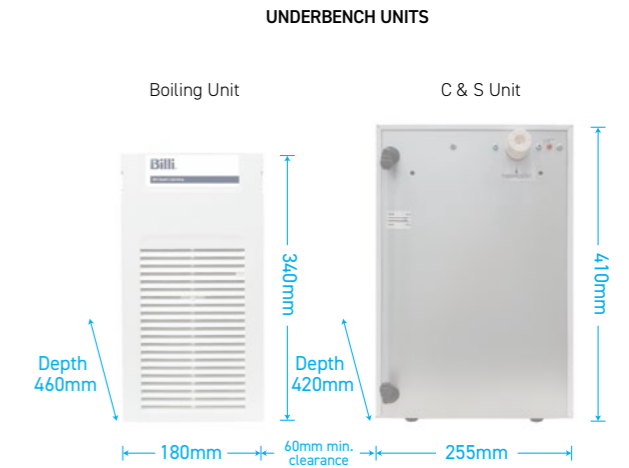

Billi Quadra Sparkling Plus

Instant boiling, chilled and sparkling filtered water system plus separate hot and cold mixer tap.

FEATURES



A CO2 gas cylinder is required and is additional to the product dimensions displayed.

DISPENSER OPTIONS + MIXER TAP OPTIONS



Product Code	Model	50° hot water capacity litres (initial drawdown)	50° hot water delivery litres per hour	Boiling water delivery (cups per hour)*	Chilled & Sparkling water delivery (cups per hour)	Power supply (amps)
906105	Quadra Sparkling Plus 15	15	85	250	200	1 x 10 1 x 15

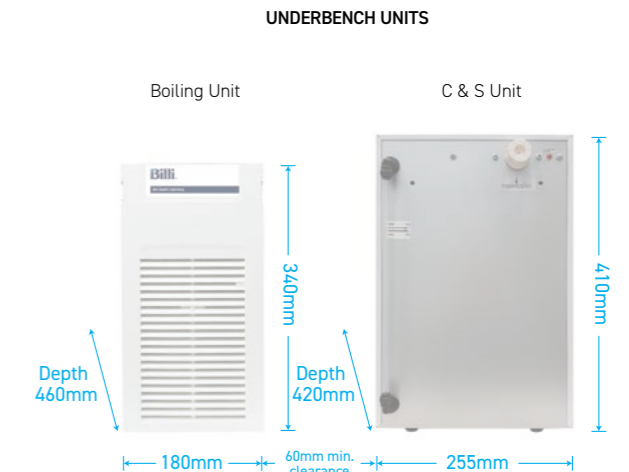

To specify your product, please combine 'PRODUCT CODE' + 'DISPENSER OPTION' + 'FINISH' + 'COUNTRY CODE' eg to specify a Billi Eco with Lever Chrome dispenser for UAE installation = 901000LCHAE



Billi Sahara

Instant boiling and ambient filtered water systems

FEATURES



DISPENSER OPTIONS



Product Code	Model	Suggested no. of people	Boiling water delivery (cups per hour)*	Still water delivery (cups per hour)	Power supply (amps)
943010	Sahara 310	up to 10	90	unlimited	10
943020	Sahara 320	up to 25	120	unlimited	10
943060	Sahara 360	up to 60	180	unlimited	10
943120	Sahara 3120	up to 120	250	unlimited	15

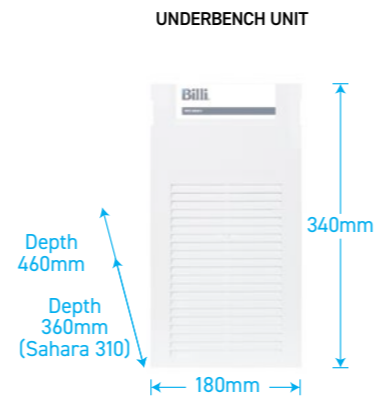

Billi Sahara Plus

Instant boiling and ambient filtered water system plus separate hot and cold mixer tap.

FEATURES



DISPENSER OPTIONS + MIXER TAP OPTIONS



Product Code	Model	50° hot water capacity litres	50° hot water delivery litres per hour	Boiling water delivery (cups per hour)*	Still water delivery (cups per hour)	Power supply (amps)
943025	Sahara Plus 320	7	25	120	unlimited	10
943065	Sahara Plus 360	9	40	180	unlimited	10
943125	Sahara Plus 3120	15	65	250	unlimited	15



Billi Alpine

Chilled and Still filtered water systems

FEATURES



DISPENSER OPTIONS



Product Code	Model	Product feature	Suggested no. of people	Chilled delivery (cups per hour)	Power supply (amps)
932060	Alpine 060	Chilled	12	60	10
932120	Alpine 120	Chilled	25	120	10
932125	Alpine 125	Chilled & Still	40	120	10

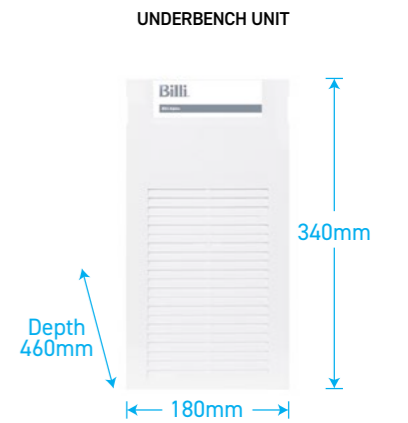

Billi Alpine Sparkling

Chilled and sparkling system

FEATURES



A CO2 gas cylinder is required and is additional to the product dimensions displayed.

DISPENSER OPTIONS



Product Code	Model	Suggested no. of people	Chilled & Sparkling delivery (cups per hour)	Power supply (amps)
933100	Alpine Sparkling 100	40	100	10
933200	Alpine Sparkling 200	80	200	10

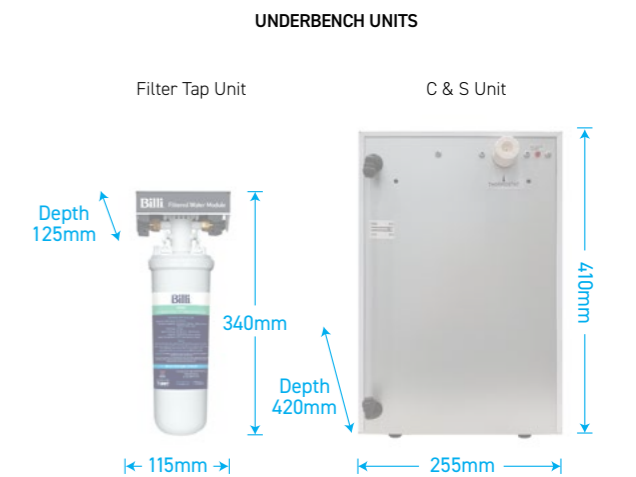

A reserve of boiling water is still available after hot water is fully drawn.

* Based on the initial number of cups of boiling water immediately available, drawn one cup every 10 seconds. For all underbench filtered water systems, consideration may be needed for usage patterns and draw-off methods. 1 cup = 170ml

To specify your product, please combine 'PRODUCT CODE' + 'DISPENSER OPTION' + 'FINISH' + 'COUNTRY CODE' eg to specify a Billi Eco with Lever Chrome dispenser for UAE installation = 901000LCHAE



STILL

Billi Filter Tap

Instant Still filtered water system

FEATURES



NO CUPBOARD VENTILATION REQUIRED



SPACE SAVING DESIGN

DISPENSER OPTIONS



Product Code	Model	Still water cups per hour
932210	Filter Tap	unlimited



p.17

X SERIES DISPENSERS



XL Levered Dispenser (XL)

The levered dispenser is streamlined and elegant. It is simply operated with position-sensitive levers.

Add 'L' and finish code to product code (901000LCH)

FINISH OPTIONS

CH	BR	MB	MW
Chrome	Brushed	Matte Black	Matte White

SPECIAL ORDER FINISHES

RG	PL	BRG	UB	GM
Rose Gold	Platinum	Brushed Rose Gold	Urban Brass	Gun Metal Grey

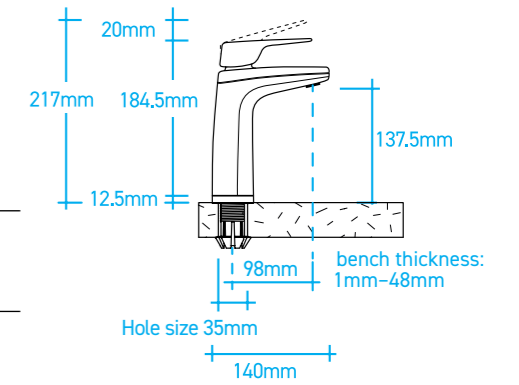

XT Touch Dispenser (XT)

The touch dispenser is an innovative, contemporary design, which has a top operating panel offering a sophisticated and clean style.

Add 'T' and finish code to product code (901000TCH)

FINISH OPTIONS

CH	BR	MB	MW
Chrome	Brushed	Matte Black	Matte White

SPECIAL ORDER FINISH

RG
Rose Gold

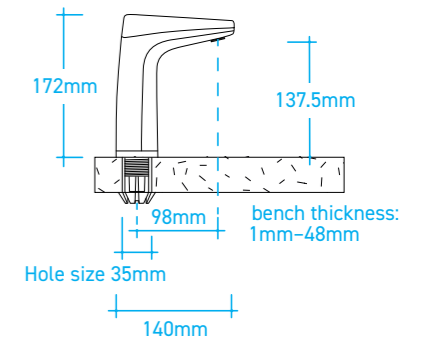

XR Remote Dispenser (XR)

The remote dispenser is another version of the lever free dispenser, however the operation panel is located away from the dispenser. This can be installed in your desired position to meet design requirements, particularly wheelchair access.

Add 'R' and finish code to product code (901000RCH)

FINISH OPTION

CH
Chrome

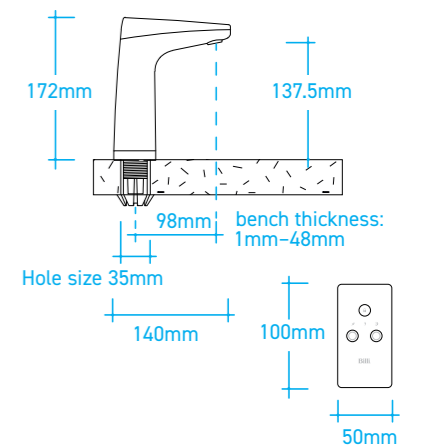

XT Dispenser in Matte Black finish with matching 70mm Riser and Font

To specify your product, please combine 'PRODUCT CODE' + 'DISPENSER OPTION' + 'FINISH' + 'COUNTRY CODE' eg to specify a Billi Eco with Lever Chrome dispenser for UAE installation = 901000LCHAE

SPECIALTY DISPENSERS



Safety Dispenser (SD)

Safety Dispenser has been specifically designed as a solution for critical care applications, such as correctional centres, mental health facilities and aged care.

Add 'V' and finish code to product code (901000VCH)

FINISH OPTION

CH
Chrome

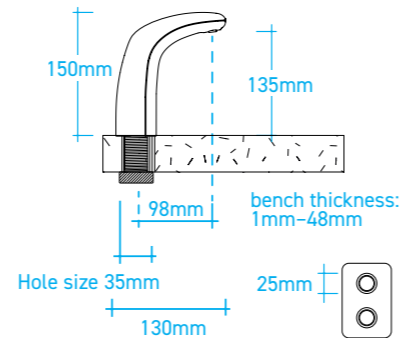

Coloured XL Levered Dispenser

Special order coloured levers provide full vision safety where LED indicators cannot be seen.

Product Code: 996300

BRAILLE PADS

Optional braille pads can be supplied with the coloured XL levered dispenser to provide further safety for vision impaired users.

FINISH OPTION

RB
Chrome with Red & Blue Levers



* Product LEDs are for image purposes only. Fully functional product operates in accordance to specification.

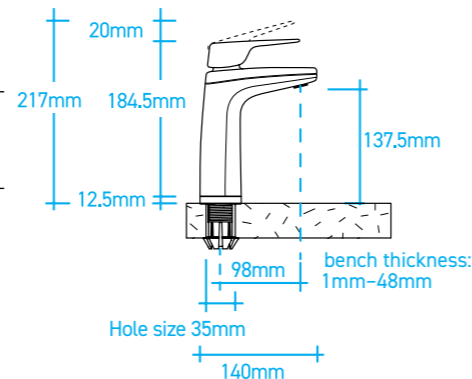

LUXGARDE™



LUXGARDE™
UVC WATER TREATMENT
CERTIFIED PURIFICATION DEVICE

Billi Luxgarde™ UVC Water Treatment Device

Billi Australia Pty Ltd has been at the forefront of the instant filtered boiling and chilled water systems industry for over 30 years. In that time the Billi name has become synonymous with innovation and quality. Billi products are celebrated for their combination of functionality, performance and contemporary aesthetics.

In recent years, the topic of water hygiene, particularly drinking water hygiene has become a larger priority for commercial Facility Managers, Hospitals, Aged Care facilities and residences alike.

While Billi's water cooled systems provide a large degree of protection simply by circulating water through the system to avoid stagnation, the ultimate protection against possible water borne pathogens is water treatment, by UVC LED purification.

To solve this problem, Billi has launched its industry leading purification device, Luxgarde™. This UVC LED purification device is non-chemical and has been developed and tested to be effective against pathogens up to **99.999%*** by ensuring reproduction of possible pathogens is stopped in its tracks.

GUARANTEED PROTECTION

- ✓ UV light eliminates up to **99.999%*** of pathogens in drinking water.
- ✓ The UVC device is positioned immediately before the dispenser meaning water is purified on demand, on its way to the vessel.
- ✓ UVC photons render pathogens incapable of reproduction preventing possible transmission.
- ✓ Drinking water is free from micro-organisms such as coliform, salmonella, legionnaire, aeruginosa, pseudomonas and the hepatitis virus.



Regular tap water



Luxgarde purified water

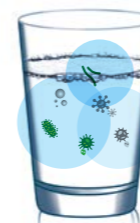

May contain:
• Bacteria
• Viruses
• Lead
• Cysts
• Chlorine
• Particulates



Purified up to 99.999% removal of water borne pathogens.



“ Luxgarde™ UVC Purification Device purifies up to **99.999%*** of your drinking water, **100% of the time** ”

*Source: Crystal CIS Lab Testing

SLIMLINE DISPENSERS



Round Slimline Dispenser **R**

Round in design with single pin lever option. Suitable for ambient or chilled water.

Add 'R' and finish code to product code (932060RCH)

FINISH OPTIONS

CH	BR	MB	MW
Chrome	Brushed	Matte Black	Matte White

SPECIAL ORDER FINISHES

RG	PL	BRG	UB	GM
Rose Gold	Platinum	Brushed Rose Gold	Urban Brass	Gun Metal Grey

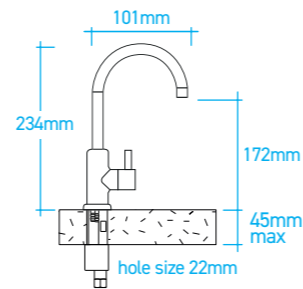

Square Slimline Dispenser **S**

Square in design with single paddle lever option. Suitable for ambient or chilled water.

Add 'S' and finish code to product code (932060SCH)

FINISH OPTIONS

CH	BR	MB	MW
Chrome	Brushed	Matte Black	Matte White

SPECIAL ORDER FINISHES

RG	PL	BRG	UB	GM
Rose Gold	Platinum	Brushed Rose Gold	Urban Brass	Gun Metal Grey

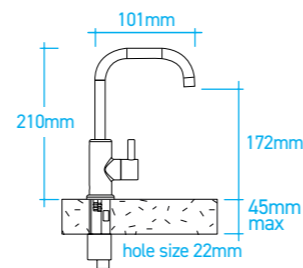

Extended Square Slimline Dispenser **E**

Extended spout allows bottles and jugs to be filled when the tap is installed on a front.

Product Code: 992130CH / 992130MB

FINISH OPTIONS

CH	BR	MB
Chrome	Brushed	Matte Black

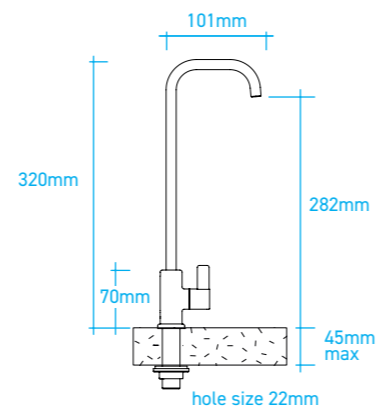

Dual Lever Dispenser **D**

Round in design with dual levers. Suitable for chilled and sparkling water.

Add 'D' and finish code to product code (933100DCH)

FINISH OPTIONS

CH	BR	MB
Chrome	Brushed	Matte Black

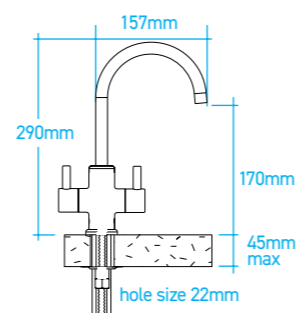

MIXER TAPWARE



Gooseneck Mixer Tap **G** **+**

Round gooseneck design suitable for plus units and offers hot and cold water in addition to X Series dispenser range. Also available as a stand-alone mixer tap.

Add 'G' and finish code to product code and dispenser option (904025LGCH)

FINISH OPTIONS

CH	BR	MB	MW
Chrome	Brushed	Matte Black	Matte White

SPECIAL ORDER FINISHES

RG	PL	BRG	UB	GM
Rose Gold	Platinum	Brushed Rose Gold	Urban Brass	Gun Metal Grey

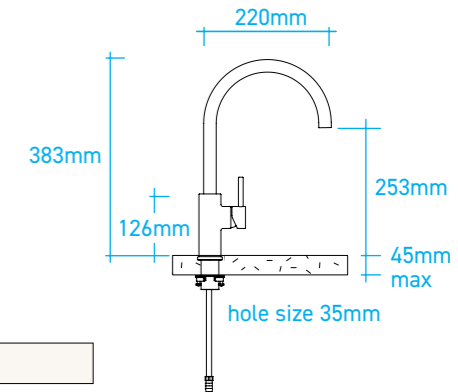

Square Mixer Tap **S** **+**

Square gooseneck design suitable for plus units and offers hot and cold water in addition to X Series dispenser range. Also available as a stand-alone mixer tap.

Add 'S' and finish code to product code and dispenser option (904025LSCH)

FINISH OPTIONS

CH	BR	MB	MW
Chrome	Brushed	Matte Black	Matte White

SPECIAL ORDER FINISHES

RG	PL	BRG	UB	GM
Rose Gold	Platinum	Brushed Rose Gold	Urban Brass	Gun Metal Grey

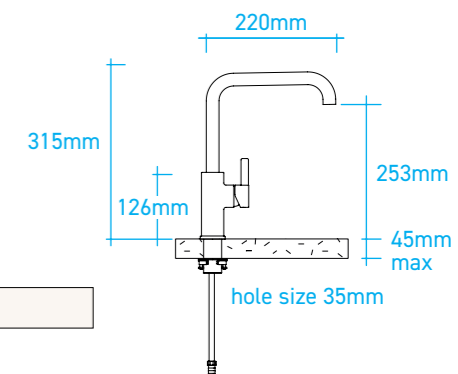

Paddle Lever Mixer Tap **P** **+**

Standard mixer tap supplied with Plus units and offers hot and cold water in addition to X Series dispenser range. Also available as a stand-alone mixer tap.

Add 'P' and finish code to product code and dispenser option (904025LPCH)

FINISH OPTIONS

CH	BR	MB	MW
Chrome	Brushed	Matte Black	Matte White

SPECIAL ORDER FINISHES

RG	PL	BRG	UB	GM
Rose Gold	Platinum	Brushed Rose Gold	Urban Brass	Gun Metal Grey

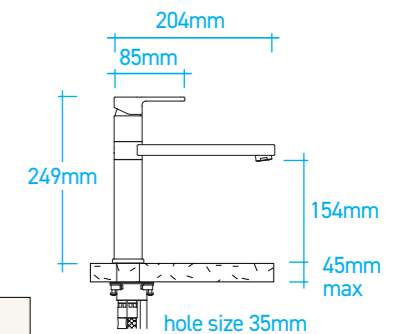

Disabled Lever - **D** For use with Paddle Lever Mixer Tap

Suitable for plus units and offers hot and cold water in addition to X Series dispenser range.

Product Code : 992121CH / 992121MB

FINISH OPTIONS

CH	BR	MB
Chrome	Brushed	Matte Black

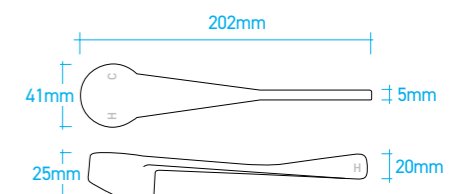

ACCESSORIES

Font with 70mm Riser

Suitable for: **XL** **XT** **XR**

Product Code: 992800

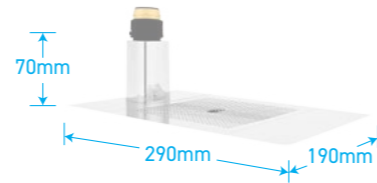

FINISH OPTIONS

CH	BR	MB	MW
Chrome	Brushed	Matte Black	Matte White

Special order finishes are available. Special orders only.

Font with 120mm Riser

Suitable for: **XL** **XT** **XR**

Product Code: 992803

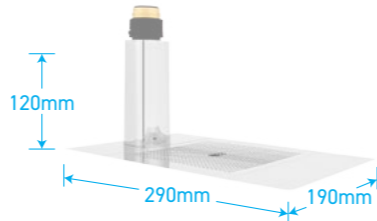

FINISH OPTIONS

CH	BR	MB	MW
Chrome	Brushed	Matte Black	Matte White

Special order finishes are available. Special orders only.

Slimline Font

Suitable for: **R** **S** **E**

Product Code: 992810

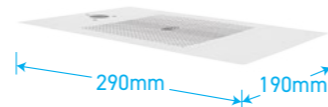

FINISH OPTIONS

CH	BR	MB	MW
Chrome	Brushed	Matte Black	Matte White

70mm Riser

Suitable for: **XL** **XT** **XR**

Product Code: 992820



FINISH OPTIONS

CH	BR	MB	MW
Chrome	Brushed	Matte Black	Matte White

Special order finishes are available. Special orders only.

120mm Riser

Suitable for: **XL** **XT** **XR**

Product Code: 992830



FINISH OPTIONS

CH	BR	MB	MW
Chrome	Brushed	Matte Black	Matte White

Special order finishes are available. Special orders only.

BILLCARE SERVICE PLANS

BilliCare provides customers with the very best in support and world class customer service experience.

Instant filtered drinking water systems require maintenance and filter replacements to ensure optimal water quality and an ongoing high level of performance. Our commitment is to make it easy for you.

All Billi offices & distributors are fully equipped to provide direct advice & support. Please visit the SUPPORT page on the Billi website for all of your support requirements.



Service Plan Benefits*

- Reduce costs and downtime
- Preventative maintenance ensures trouble-free operation for peace of mind
- Only accredited service technicians will service your systems
- Work with a single service company nationally to simplify call bookings

*Benefits will vary depending on plan chosen

PREMIUM FILTRATION



Billi™

ADVANCED
MULTI-STAGE
FILTRATION
TECHNOLOGY

Billi prides itself on offering world class water filtration products and continues to partner with global leading experts in all areas of water filtration.

- Activated carbon fibre
- High level chlorine & chemical adsorption
- Turbidity reduction
- Chemical taste & odour reduction
- Graded density structure to remove cysts with low pressure drop (994052 only)

Billi & BWT

Billi has partnered with BWT to provide the highest quality filters. BWT is Europe's largest water treatment products company.

Billi's range of premium filters utilise BWT's unique Fibron X technology. Fibron X technology has a graded density profile ensuring maximum performance and capacity. Billi's filter range provides superior water quality, consistent filter life and peace of mind.

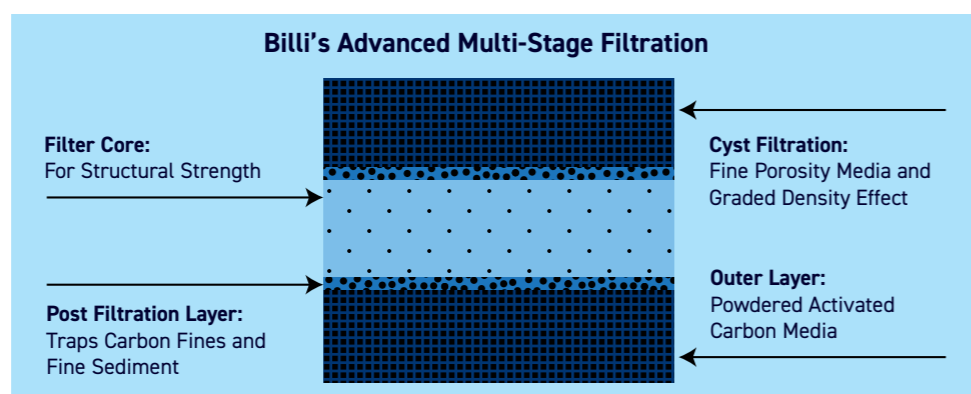

Billi Premium Filtration vs Standard Filtration

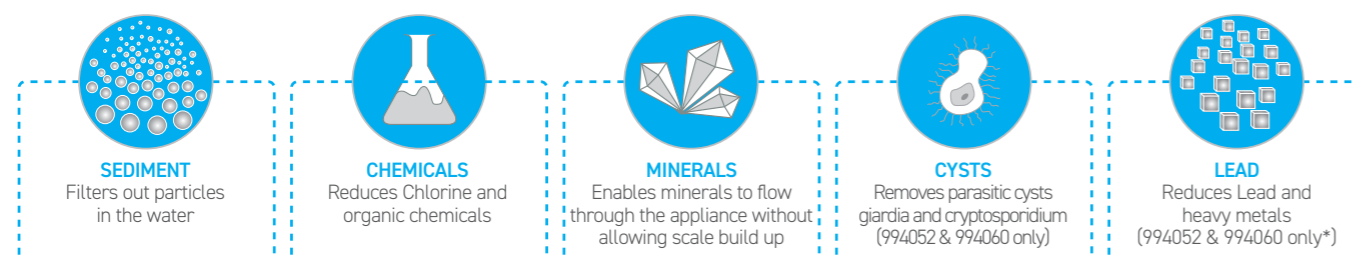
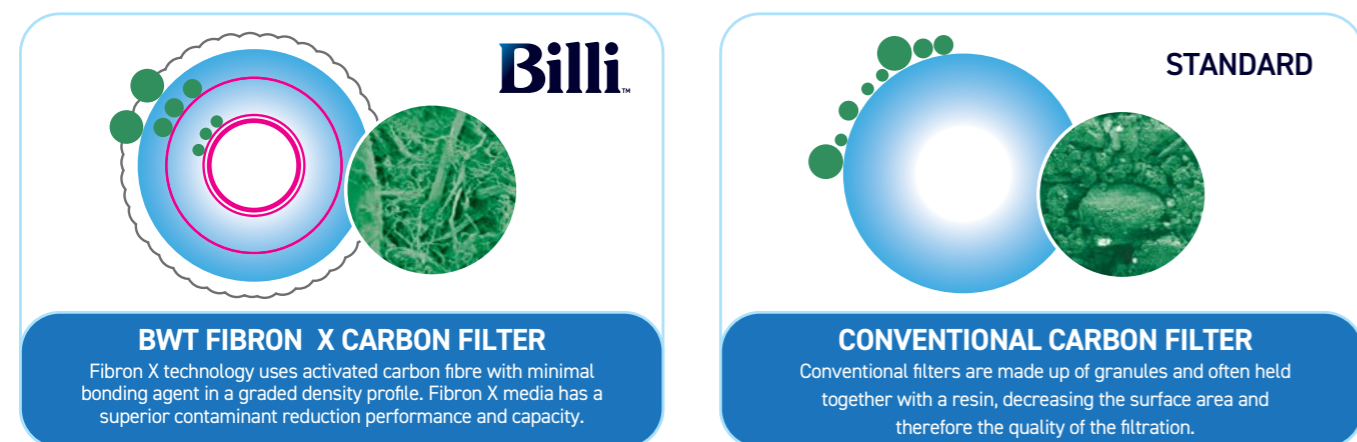

Billi filters have been independently tested and certified by IAPMO to international standards and Australian Watermark. Billi filter performance testing is conducted in accordance with international standards NSF, WRAS and Watermark.

*Lead Reduction on 994052 + 994060 @ 98.93%

Replacement Filters

Periodic replacement of filters is necessary to maintain water quality. Genuine replacement Billi filters are available on our website and from your local approved supplier. Filters are also available to suit the needs of different water supply areas.

Billi recommends you change your filter at least every 12 months. Replacing your filter cartridge is simple. Solid amber dispenser icons indicate when replacement is due. The swing change filter simply swings forward and slides out. Fitting the new filter is just as easy – simply slide the filter in and swing it back. The cartridge locks into place.

All Billi genuine filters come with a digital lockout feature to ensure single use and hygiene.

Easy filter change.
Simply swing forward and slide out to replace filter.



5 Micron Fibron X® Replacement Filter 994051

Nominal Filter Rating | 5 Micron
Filtration Capability | Sediment, Chlorine, Taste & Odour
Flow Rate | 3.8lpm
Water Pressure | 80 kPa min - 860 kPa max
Capacity | 30,000 litres (Chlorine reduction)
Water Temperature | 38°C max; Must not freeze

0.2 Micron Fibron XC® Replacement Filter 994052

Nominal Filter Rating | 0.2 Micron
Filtration Capability | Sediment, Chlorine, Taste & Odour
Parasitic Cysts, Lead
Flow Rate | 3.8lpm
Water Pressure | 80 kPa min - 860 kPa max
Capacity | 30,000 litres (Chlorine reduction)
Water Temperature | 38°C max; Must not freeze

HSD Fibron XT® Replacement Filter 994054

Filtration Capability | Sediment, Chlorine, Taste & Odour
Flow Rate | 3.8lpm
Water Pressure | 80 kPa min - 860 kPa max
Capacity | 30,000 litres (Chlorine reduction)
Water Temperature | 38°C max; Must not freeze

Sediment Only Replacement Filter 994056

Filtration Capability | Sediment
Flow Rate | 3.8lpm
Water Pressure | 80 kPa min - 860 kPa max
Capacity | 30,000 litres
Water Temperature | 38°C max; Must not freeze

0.2 Micron HF Sediment Only Replacement Filter 994060

Filtration Capability | 0.2 Micron HF Sediment
Flow Rate | 3.8lpm
Water Pressure | 80 kPa min - 860 kPa max
Capacity | 10,000 litres
Water Temperature | 38°C max; Must not freeze



Quality ISO 9001



*On Eco, Quadra and Quadra Plus models only.

Standard Warranty

All components of the drinking water systems are covered by a 24-month warranty.

Commitment to Quality

A strong commitment to quality is as important to Billi as style, function and innovation. Recognising the importance of reliability to customers, all Billi water systems are manufactured to strict quality standards.

Every system is designed to provide the highest possible standards of efficiency and energy savings.

Certifications

Every Billi drinking water appliance is manufactured under a certified quality control system.

All Billi commercial range models have been tested and comply with all required standards including:

- G-Mark;
- Watermark: WM-021525;
- Certified to AS/NZ3498 and AS/NZ 4020;
- ISO9001: 2015, QEC 11627;
- Section J6.6 of the BCA;
- HACCP: PE-872-WAT-1-02;
- WELL Cornerstone Member;
- GreenTag.



Chrome XL Levered Dispenser with matching 70mm riser and font





Billi™

Billi Australia Pty Ltd
42 Lucknow Crescent,
Thomastown, Victoria
3074 Australia

P 1800 812 321
W www.billi.com.au

Connect with us



All details are subject to change without notice. Not all products available in all countries. Refer to local distributor.
All goods are sold subject to our published terms and conditions. Billi™ is a registered trademark.

6657_BILLI_COMM_UAE_10.23